

MATRIX

CONNEXUS HOME

CX50





3 ENGLISH  
XX FRANÇAIS  
XX ESPAÑOL

## BEFORE YOU BEGIN

The Connexus Home CX50 is an innovative platform that provides solutions for functional training in the home. The CX50 allows users to do suspension strap training, resistance band training and numerous body-weight exercises utilizing the platform and weighted training bar.

## LOCATION OF THE EQUIPMENT

Place the front of the equipment near a wall and leave a little space for attaching straps and bands.

TOTAL AREA:

- The recommended free area and training area equals a total area of 8 x 10 feet (244 x 305 cm).
- The free area surrounding the equipment should be 2 ft (61 cm).

## LEVELING THE EQUIPMENT

The equipment should be level for optimum use. Once you have placed the equipment where you intend to use it, raise or lower one or two of the four adjustable levelers located on the bottom of the frame.

A carpenter's level is recommended.

NOTE: There are four levelers on the equipment.

## WARNING!

Our equipment is heavy, use care and additional help if necessary when moving. Failure to follow these instructions could result in injury.

## MAINTENANCE

1. DO NOT use any equipment that is damaged and or has worn or broken parts. Use only replacement parts supplied by Customer Tech Support. Contact information is located on the information card.
2. MAINTAIN LABELS AND NAMEPLATES: Do not remove labels for any reason. They contain important information. If unreadable or missing, contact Customer Tech Support for a replacement.
3. MAINTAIN ALL EQUIPMENT: Preventative maintenance is the key to smooth operating equipment. Equipment needs to be inspected at regular intervals.
4. Ensure that any person(s) making adjustments or performing maintenance or repair of any kind is qualified to do so.

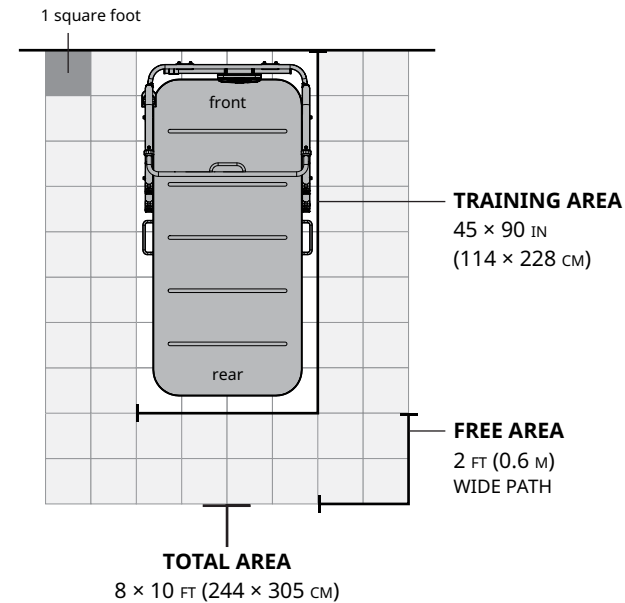

## PRODUCT SPECIFICATIONS

Class H (Home) equipment for indoor use only.

Max User Weight, Max Pull-up/Training Bar Load	159 kg / 350 lbs.
Max Resistance Band Training Load	91 kg / 200 lbs.
Product Weight	141.5 kg / 312 lbs.
Resistance Band Max Stretch/Load	Gray: 3x length, 25 lbs. Black: 3x length, 50 lbs. Orange: 3x length, 100 lbs.
Overall Dimensions (L x W x H)	228 x 114 x 216 cm / 90 x 45 x 85"

## MAINTENANCE CHECKLIST

ACTION	FREQUENCY
Inspect Hardware	Monthly
Inspect Frame	Monthly
Clean Machine	As Needed





# ASSEMBLY

## WARNING!

There are several areas during the assembly process where special attention must be paid. It is very important to follow the assembly instructions correctly and to make sure all parts are properly tightened. Failure to correctly follow the assembly instructions provided could result in loose connections and noise from the equipment.

## SERIAL NUMBER LOCATION

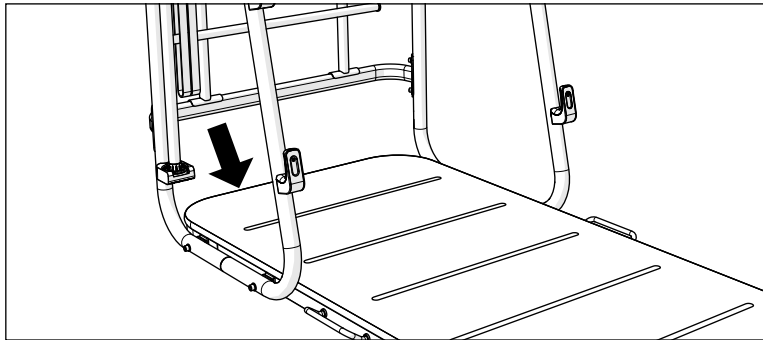

Before proceeding, find the serial number located on a barcode sticker and enter it in the space provided below.

## SERIAL NUMBER

## MODEL NAME

**MATRIX CONNEXUS HOME CX50**

\* Use the information above when calling for service.

## UNPACKING

Unpack the equipment where you will be using it. Place the carton on a level flat surface.

## TOOLS INCLUDED:

- 8 mm Allen Wrench
- 10 mm Allen Wrench

## PARTS INCLUDED:

- 1 Activity Base
- 1 Left Frame Upright
- 1 Right Frame Upright
- 1 Pull-Up Bar
- 2 Connection Covers
- 1 Upper Crossbar
- 1 Lower Crossbar
- 1 Power Grid
- 2 Base Anchors
- 1 Training Bar
- 6 Resistance Bands
- 1 Smart Storage Chalkboard
- 1 Hardware Kit

## NEED HELP?

If you have questions or if there are any missing parts, contact Customer Tech Support. Contact information is located on the information card.

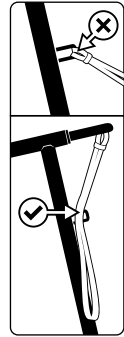
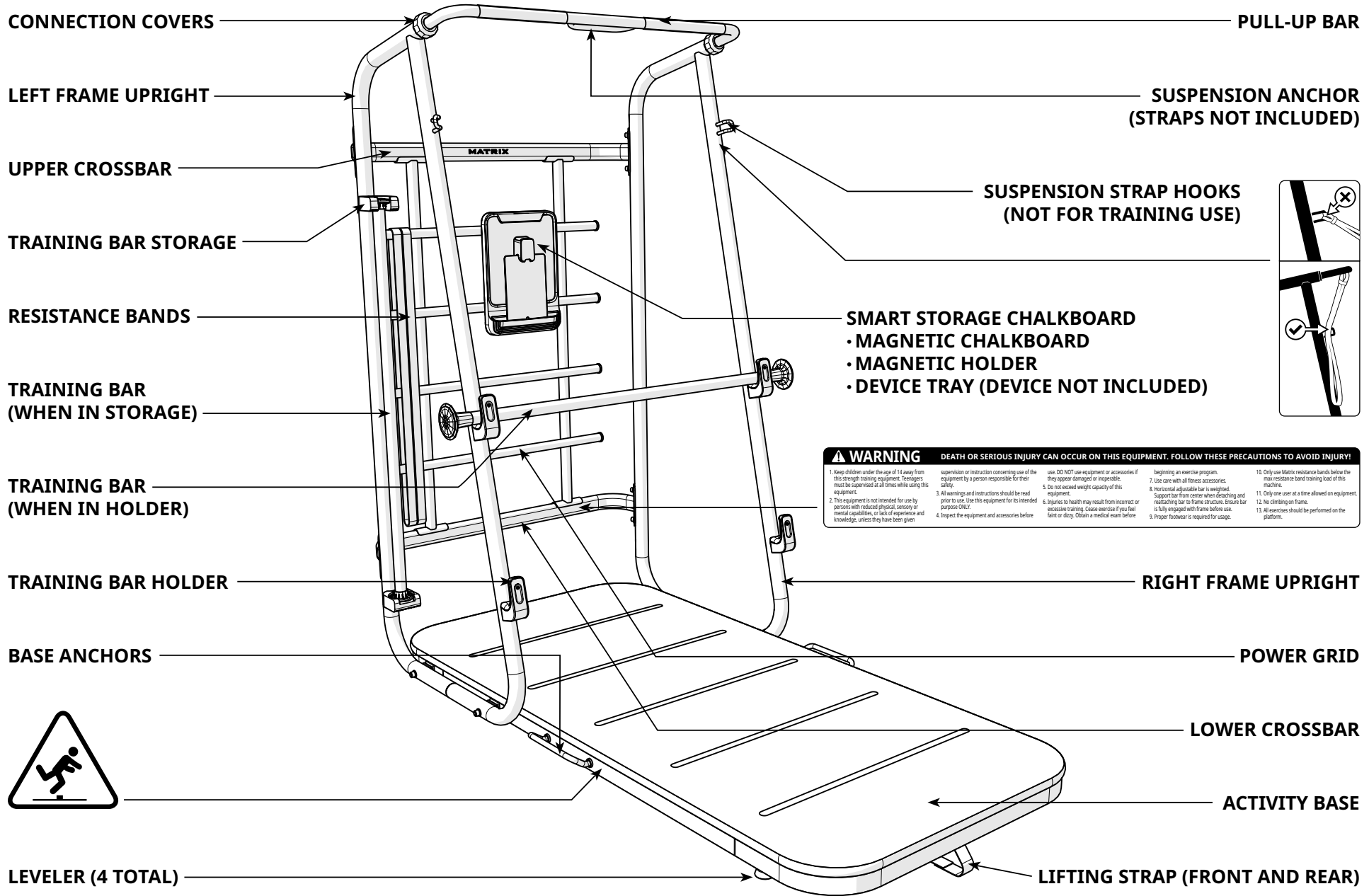

**⚠ WARNING DEATH OR SERIOUS INJURY CAN OCCUR ON THIS EQUIPMENT. FOLLOW THESE PRECAUTIONS TO AVOID INJURY!**

<ol style="list-style-type: none"> <li>1. Keep children under the age of 14 away from this strength training equipment. Teenagers must be supervised at all times while using this equipment.</li> <li>2. This equipment is not intended for use by persons with reduced physical, sensory or mental capabilities, or lack of experience and knowledge, unless they have been given</li> </ol>	<ol style="list-style-type: none"> <li>3. All warnings and instructions should be read prior to use. Use this equipment for its intended purpose ONLY.</li> <li>4. Inspect the equipment and accessories before</li> </ol>	<ol style="list-style-type: none"> <li>5. Do not exceed weight capacity of this equipment.</li> <li>6. Injuries to health may result from incorrect or excessive training. Cease exercise if you feel faint or dizzy. Obtain a medical exam before</li> </ol>	<ol style="list-style-type: none"> <li>7. Use care with all fitness accessories.</li> <li>8. Horizontal adjustable bar is weighted. Support bar from center when detaching and reattaching bar to frame structure. Ensure bar is fully engaged with frame before use.</li> <li>9. Proper footwear is required for usage.</li> <li>10. Only use Matrix resistance bands below the max resistance band training load of this machine.</li> <li>11. Only one user at a time allowed on equipment.</li> <li>12. No climbing on frame.</li> <li>13. All exercises should be performed on the platform.</li> </ol>
--	--	---	--





1

Hardware For Step 1		
Description	Qty	
A Bolt	4	
B Lock Washer	4	
C Flat Washer	4	

Torque Value
15 Nm / 11 ft-lb

ENGLISH

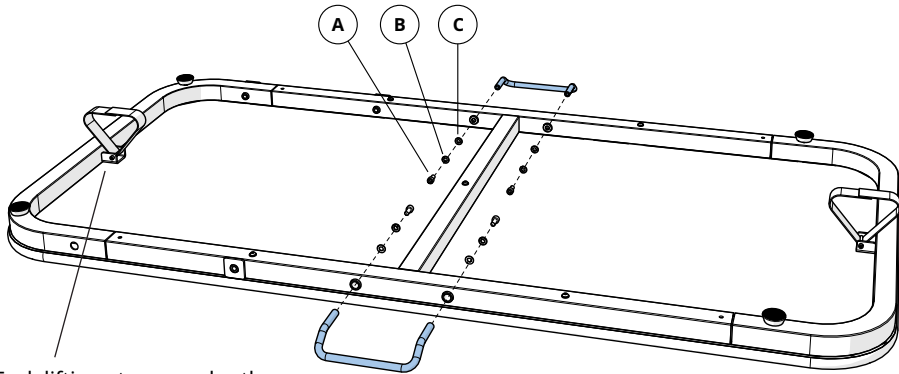

Tuck lifting straps under the base after flipping it over to avoid a tripping hazard.

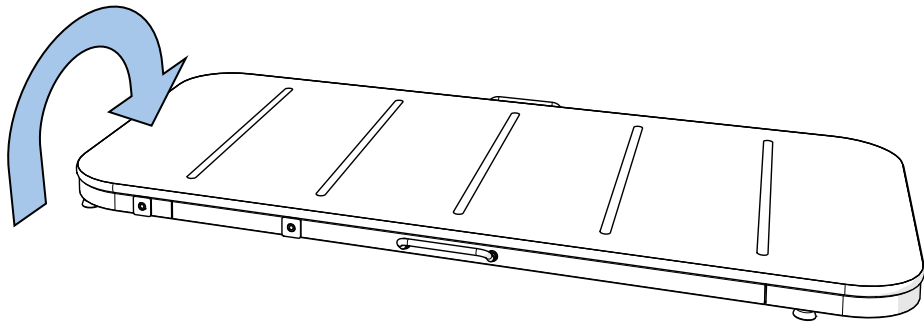

2

Hardware For Step 2		
Description	Qty	
D Bolt	4	
E Lock Washer	4	

Torque Value
50 Nm / 37 ft-lb

**IMPORTANT:** Do not tighten bolts until step 6 is complete.

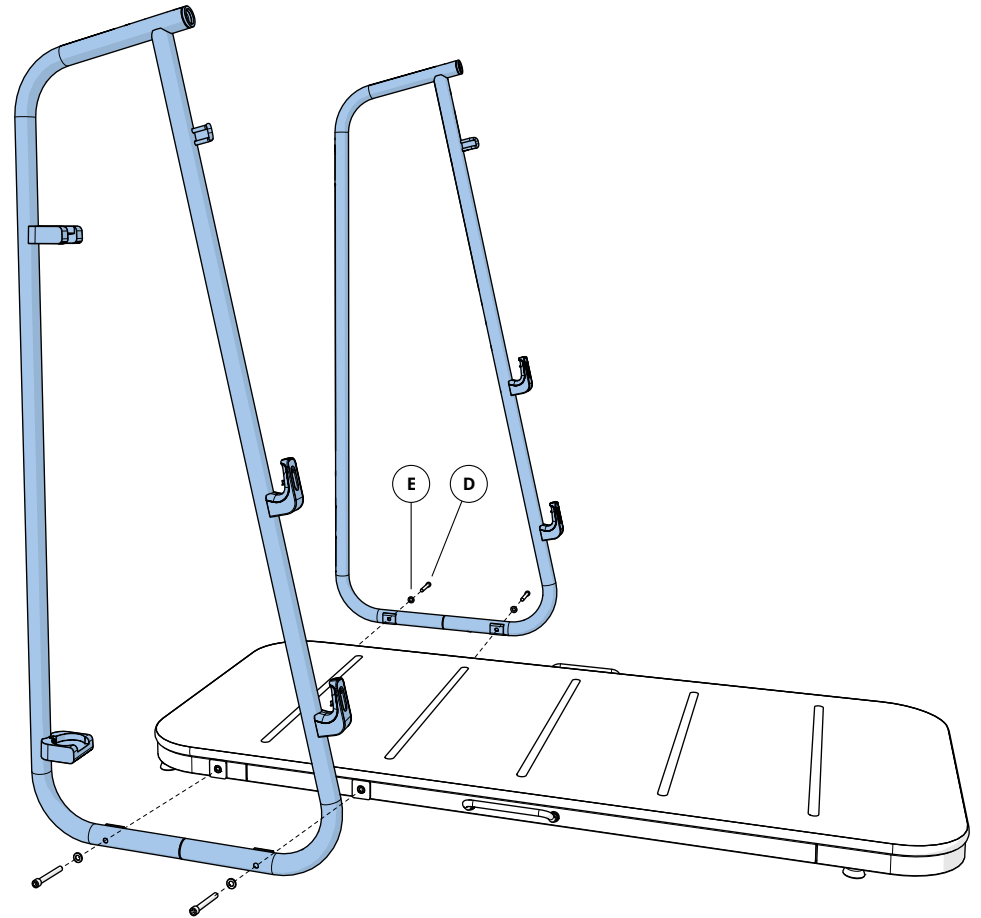

# 3

Hardware For Step 3		
Description	Qty	
A Bolt	2	
Torque Value		
15 Nm / 11 ft-lb		

**IMPORTANT:** Do not tighten bolts until step 6 is complete.

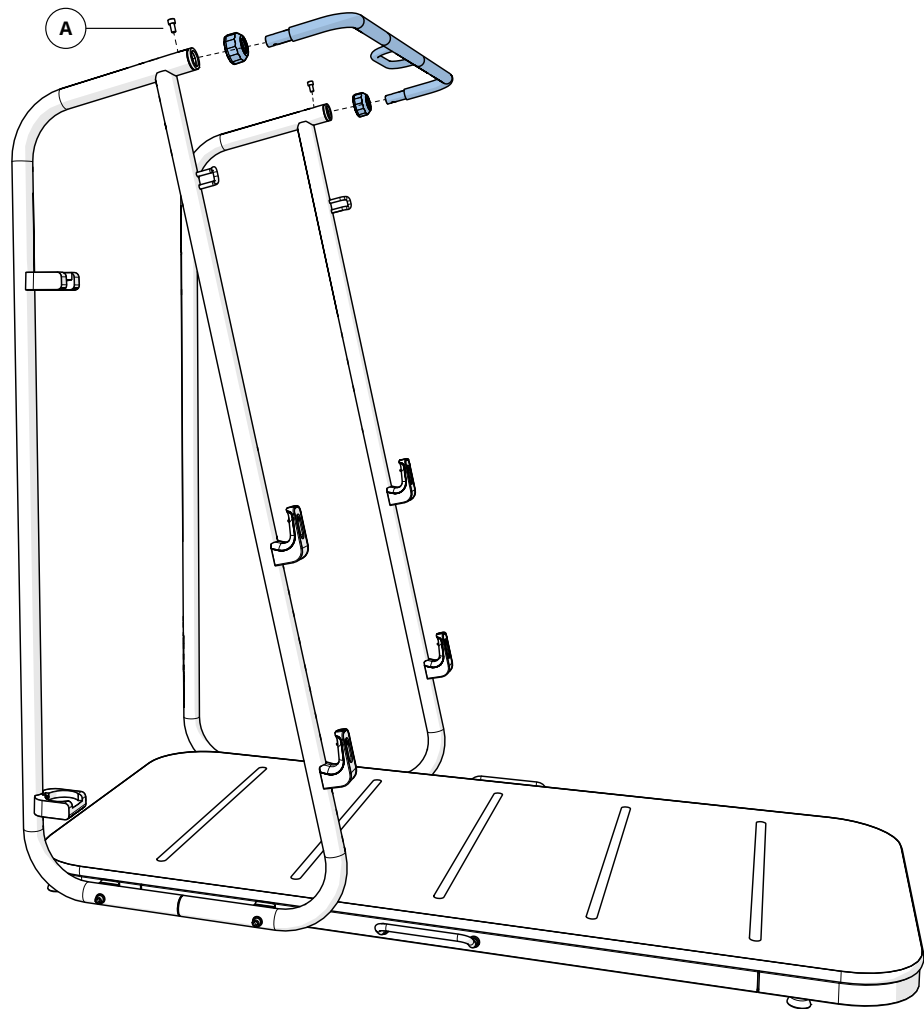

# 4

Hardware For Step 4		
Description	Qty	
A Bolt	4	
B Lock Washer	4	
C Flat Washer	4	
Torque Value		
15 Nm / 11 ft-lb		

**IMPORTANT:** Do not tighten bolts until step 6 is complete.

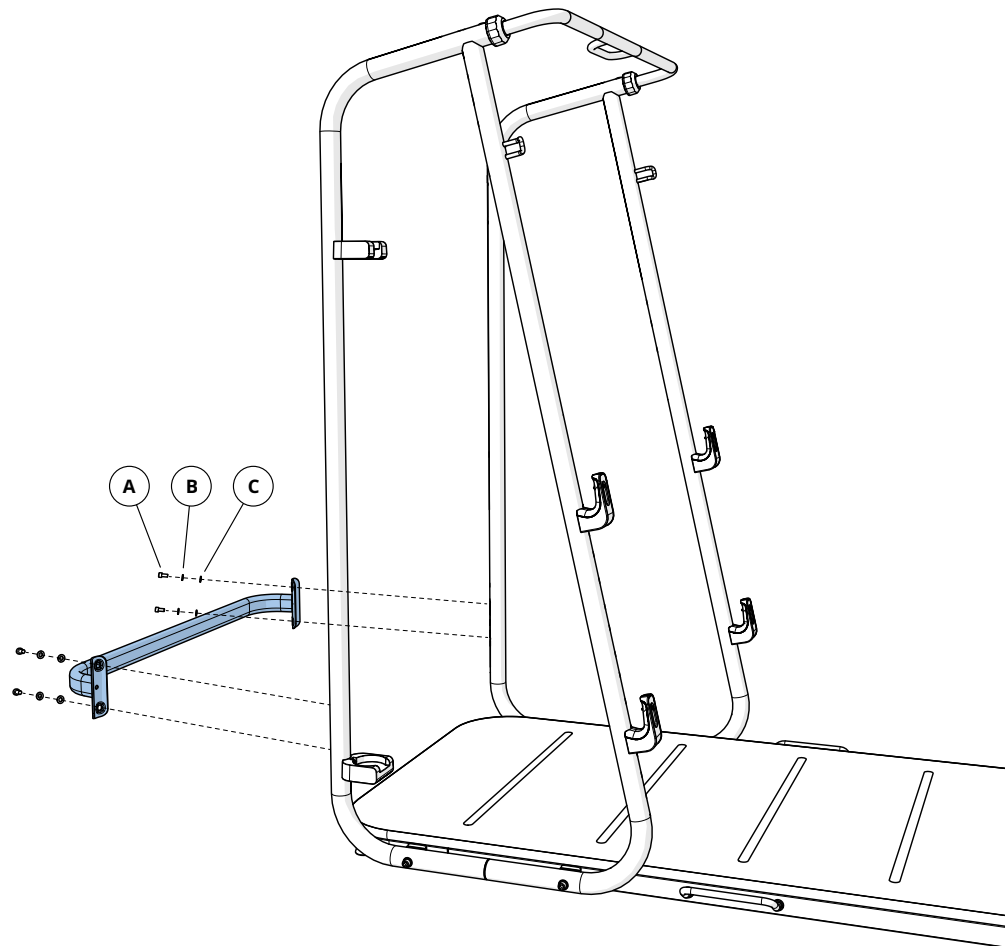



5

Hardware For Step 5		
Description	Qty	
A Bolt	4	
B Lock Washer	4	
C Flat Washer	4	

Torque Value
15 Nm / 11 ft-lb

**IMPORTANT:** Do not tighten bolts until step 6 is complete.

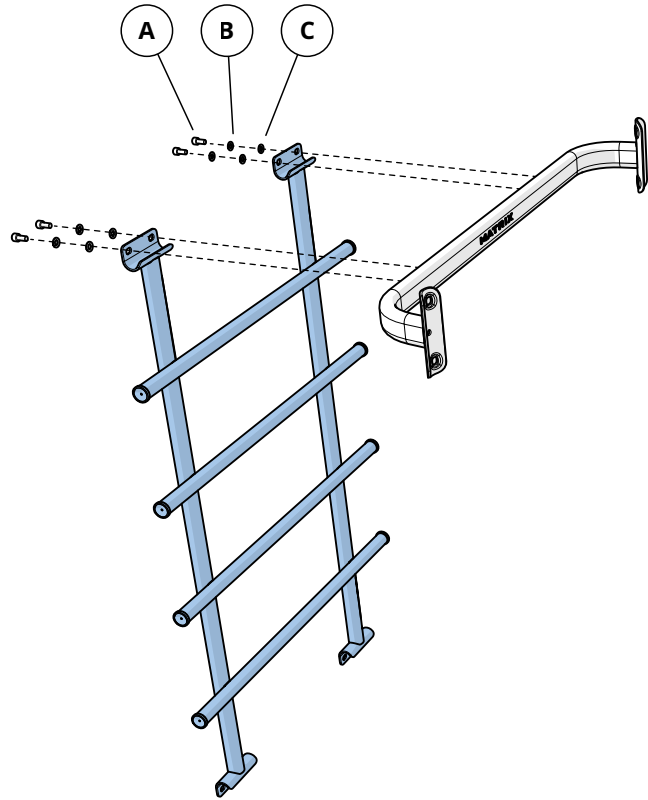

6

Hardware For Step 6		
Description	Qty	
A Bolt	8	
B Lock Washer	8	
C Flat Washer	8	

Torque Value
15 Nm / 11 ft-lb

Tighten all bolts from steps 1-6. Tighten to torque values listed in each step.

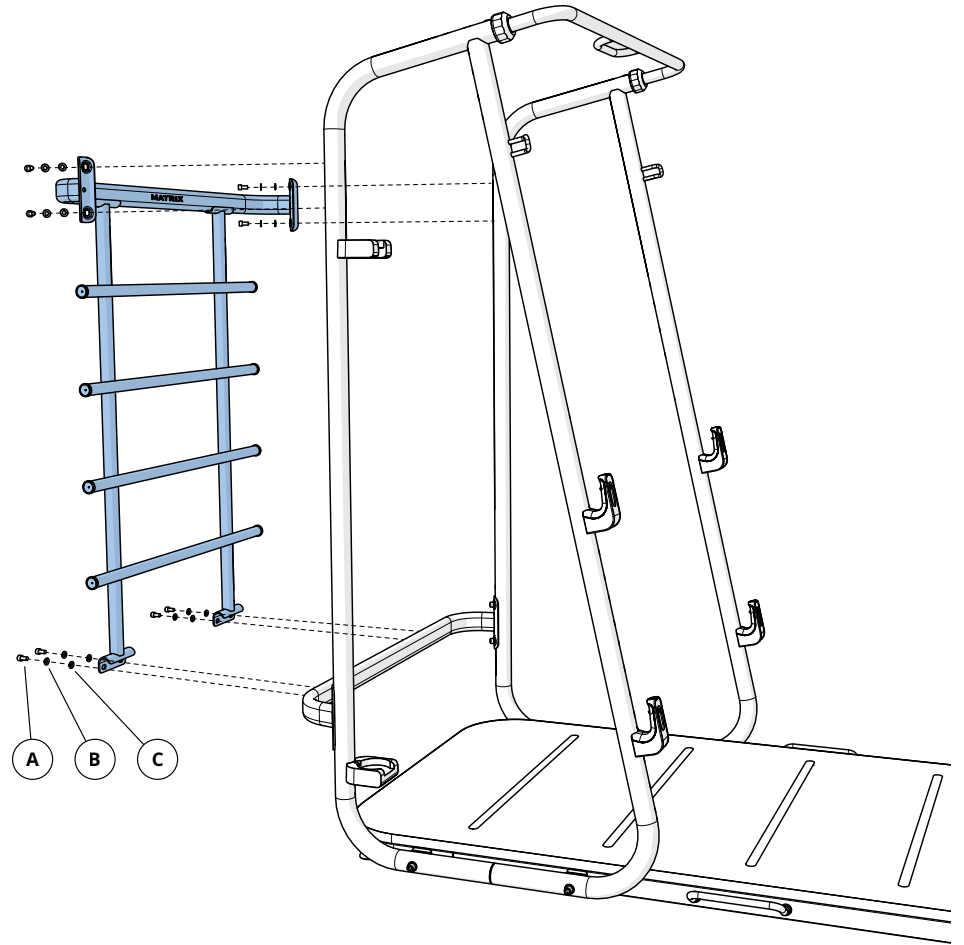



7



8

ASSEMBLY COMPLETE!



ENGLISH

# MATRIX



CX50

© 2017 Johnson Health Tech

Rev 1.0 A